



C700 Users Guide

Josephson Engineering, Inc.

329A Ingalls Street
Santa Cruz, California
+1 831 420 0888
www.josephson.com

©2014 Josephson Engineering

This Guide was previously published as the "Series Seven Users Guide" but since there are now more microphones in the Series Seven besides the C700, we decided to revise the title to avoid confusion.



C700/Series Seven Users Guide

Josephson C700 microphones provide extraordinary flexibility for the user. Any directional pattern from omni to figure-8 may be derived, and with the C700S, an unlimited number of “virtual microphones” pointing in different directions can be generated using the side-facing channel produced by the side-facing figure-8 capsule. This guide is intended to help the user understand the basic concepts of multiple capsule mid-side stereo and surround techniques, as made possible by the C700. One approach to explaining this idea is to reduce it to the mathematics of monopole and dipole transducers (but we’ll save the math for the appendix, it’s not needed to fully understand and use the microphone as an instrument.)

A major benefit of recording with the C700 is the ability to capture and save the raw audio components during a session, which can then be used to generate any number of directional patterns in playback. For a mono track, this allows the directional pattern to be adjusted during a track as a performer moves around, for instance.

This User’s Guide applies to the both the C700A and the C700S. The only difference between the microphones is that the C700S has an additional channel for side information, that allows the direction of the main microphone pattern to be changed. We are mentioning only a few of the possibilities here; once you have a good understanding of how the patterns are added together to form new patterns, your own creativity and experience will take over in suggesting other mixtures of these channels that will produce other patterns.

The key concept to learn is that the microphone produces a separate output for each of its capsules. The user mixes these outputs together to derive any desired directional pattern. In the C700S, there is a third output, and adding this output into the mix allows the resultant directional pattern to be steered anywhere on the horizontal plane around the microphone. We have made a control console to derive patterns in the field, but we have found it much more effective to record the raw signals and matrix them afterward. The diagram of the control console is included in the Appendix for reference.

The microphone is rated for standard P48 phantom power, please note that all outputs of the microphone must be connected to phantom power before it will function properly.

Omnidirectional, or pressure microphone (W channel)

Omnidirectional microphones are the simplest. The moving element or diaphragm is open to sound on one side, and sealed on the other. Sound pressure causes the diaphragm to move inward, regardless of the direction. For low and mid-frequency sound waves, the wavelength is much larger than the size of the microphone – so the pressure wave simply flows around the microphone, pushing in on all surfaces regardless of its origin. These are called pressure microphones because they mainly respond to sound pressure. We use a small single diaphragm

omni capsule for the W channel; this is the best way to assure superior off-axis tracking of the response pattern with minimal response changes.

Figure-8, or gradient microphone (X channel)

Figure-8 microphones have moving elements that are open to sound both front and rear. Both sides are equally sensitive. Sound pressure coming from the front causes the a positive electrical output. Sound pressure coming from the rear causes a negative electrical output. Sound coming from the side pushes equally in both directions, so there is no output. Figure-8 microphones are sometimes called pressure gradient or velocity microphones, because their output can be proportional to the gradient or difference between front and back pressure. We use a large dual-diaphragm capsule for the figure-8 signal because its symmetrical construction and high sensitivity produce a uniform front-back pattern with very tight nulls at the sides and a reduced noise floor.

Making a cardioid from an omni and a figure-8

The C700A and C700S include an omni microphone and a forward-facing figure-8 microphone. We call the omni or pressure signal “W” and the front-facing figure-8 “X”. The microphone outputs are directly driven by the W and X elements. A whole family of directivity choices is available by mixing W and X. Mixing them at equal levels produces a cardioid. To understand this, remember that sounds arriving from the rear produce an output that’s out of phase with the output that would result if they arrived from the front. If two equal but out-of-phase signals are mixed together, the result is zero. If one signal is a little bigger than the other, the result of mixing is simply the difference between the two signals.

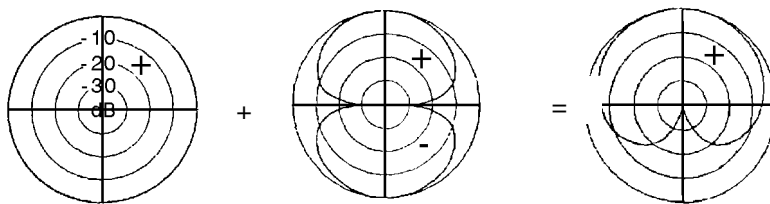

W signal plus X signal equals cardioid

In the cardioid case, for sound coming from the front, the output from W and X are equal. Add them together, and the sum is double the value of the individual signals because the omni signal adds to the signal from the front side of the figure-8. For sounds arriving from the side, the W microphone still picks up with uniform sensitivity but the X microphone has no output, so the summed output is the same as for the W microphone alone. For sounds arriving from the rear, the omni and figure-8 signals are again equal but now out of phase, so the summed signal is zero. Note the + and - symbols, which are there to remind you that the front side of the figure-8 is in phase with the W signal, while the rear side is out of phase.

Other patterns

All of the possible patterns can be imagined by thinking of the X (figure-8) pattern, and what happens to the signal if you add some W (omni) to it. If the X signal is constant, and a small amount of W is added, the front lobe of the figure-8 grows a little because the signals add, and the rear lobe shrinks a little, because the W signal cancels the out-of-phase rear lobe of the X signal. When the W signal is increased to a point 10 dB below the X signal, the pattern has changed to a hypercardioid, with the rear lobe about 10 dB reduced from the original X signal. Adding W to X

also moves the position of the figure-8 null, which is normally at 90° and 270°. Remember, when the W and X signals are equal, the side nulls are moved all the way back to 180° and merge to form a cardioid pattern. Whenever the W signal is less than X in the mix, the null will be somewhere between the sides and the rear. If the W signal is larger than the X signal, there will never be a complete null, but rather a near-omni pattern that is weighted toward the front, assuming that W and X signals remain in phase. There are different names for these patterns, including “hypo-cardioid” “wide cardioid” and “subcardioid.” Hypercardioid is usually defined as 9.5 dB more of the X signal than the W, supercardioid occurs when X signal is 4.6 dB higher than the W.

Reverse direction

What happens when you reverse phase of the X signal? All of the same patterns described so far, but facing toward the rear of the microphone rather than the front. There is of course some change in high frequency response due to the fact that the W capsule is facing forward, but for low and middle range frequencies it is truly omnidirectional. This operation can be described either as the W signal *minus* the X signal, or as the W signal plus the *minus* X signal.

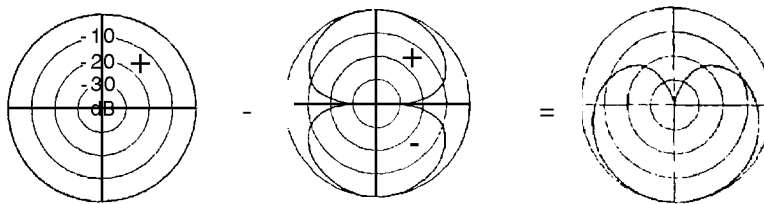

W signal minus X signal equals reversed cardioid

Summary of Summing

- Control the pattern by selecting the ratio of W to X

Steering (C700S only)

The C700S includes another figure-8 capsule at 90° to the “X” capsule, providing a signal from a side-facing microphone capsule called “Y” to allow the “X” figure-8 signal to be steered in any direction. If signals from two coincident, orthogonal figure-8 microphones are summed in any ratio, the result is always still a figure-8 pattern, but pointing in a different direction. Remember that all the patterns derived with the W and X signals were facing along a front-back axis. Now consider what would happen if this axis were rotated. The Y signal faces left, so patterns derived with all Y and varying amounts of W added will be about the same as the patterns derived with X and varying amounts of W – only now they point 90° to the left. If we use a mixture of X and Y, the resulting pattern will be pointing anywhere from 90° left (all Y) to 45° left (equal proportions of X and Y) to straight in front (all X). If we continue around and invert the phase of the Y signal, it’s the same as having the Y capsule pointing right, so we can now derive all the patterns but pointing anywhere from 0° to 90° right. Continuing around, if we invert the phase of the X channel, the patterns are facing toward the left rear, and if we invert the phase of both the X and Y channels, the patterns face toward the right rear.

Summary of Steering

- Virtual direction of X may be changed by adding Y
- Any pattern created with W and X is therefore rotated by adding Y

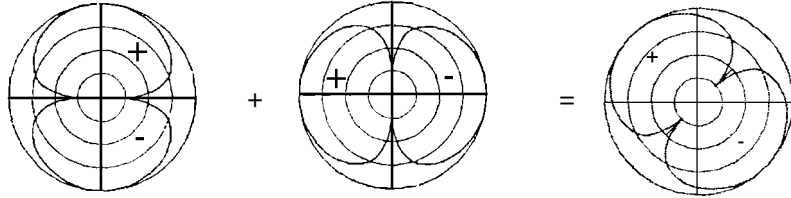

X signal plus Y signal equals left-front facing figure-8

To recap, we can rotate the direction of the figure-8 signal any amount by adding a different amount of Y to X. The resulting pattern, regardless of the relative amounts of the two signals, will always be figure-8. We can call the summed X and Y signal "D." The front lobe of the D signal will be pointing somewhere on a 360 degree circle according to the relative phase of the components:

$(X) + (Y)$	$(X) + (-Y)$
D = LF	D = RF
D = LR	D = RR
$(-X) + (Y)$	$(-X) + (-Y)$

MS equivalent

If you are familiar with Mid-Side or MS stereo, you will recognize the Y channel as being the same as the S channel in MS. Any MS technique can be realized with the C700S. Use the W and X channels summed to produce the forward-facing M signal of the desired pattern, and the Y channel for the S.

XY equivalent

The most basic intensity stereo pickup consists of cardioid microphones spaced 45° either side of the center line. This is often called "XY stereo." Note, this is a different use of "X" and "Y" than the names we've adopted for the C700 output channels. XY stereo left and right channels can be created from the M and S signals exactly as described: left is $M+S$, right is $M-S$.

Experiment

Start with the basic X signal and move the sound source around to the side of the microphone. Notice the sharp null at 90° . Sounds that have asymmetrical waveforms will sound different (as with all figure-8 microphones) when moved to the rear of the mic, due to phase reversal. This is particularly true if the sound source is the person who's listening to the output through headphones, because of mixing the direct in-the-head sound paths with the headphone path. Begin adding a little W signal, for example at 20 dB below the X signal. Notice that the sound in front has changed character; the proximity effect is reduced somewhat. The side-facing nulls have moved back $10\text{-}20^\circ$ and the rear sensitivity is reduced. Continue adding W to the X signal, and the null will continue to move toward the back. Adjust the ratio of W and X to be equal, and note that the null is at 180° .

Tracking

We recommend that the raw W and X signals be recorded on a tracking master (and the Y, if a C700S microphone is being used). That way, all the directional pattern and angle choices can be made in mixdown and your options for pattern selection remain.

For vocals, this can be particularly powerful. After the session, you may decide that using a more omnidirectional pattern with the singer up close to the microphone is preferable to working at a greater distance with a more directional pattern. The ratio of direct to "room" or ambient/reverberant sound can be controlled either way - by working at different distances or by controlling the pattern of the microphone.

Equalization and Proximity Effect

Another powerful tool available to the C700 user is selective equalization of the omni and figure-8 capsules. Traditional single-output microphones have a fixed set of characteristics including directional patterns that vary with frequency and distance. You might decide for instance that you need a tight hypercardioid pattern above 2 kHz for control of high frequency ambient sound, but have a vocalist who is moving around a lot causing low frequency response changes due to proximity effect. The desired pattern might nominally be a cardioid in the mid-band, but tending to omni at the low frequencies and hypercardioid at high-mid frequencies. To accomplish this, you would roll off the low frequencies and boost the mid-high frequencies of the X signal.

Stereo on a Simple Mixer

The simplest way to use a C700S for stereo with a mixer requires only a ywe cord built with one of its outputs reversed in phase. See Appendix C1 for a wiring diagram, this cable is not included with the microphone. Four mixer channels will be needed. The W and X channels are connected to the first two mixer channels, which are panned center. The Y channel is connected to an inverting ywe cord; the straight-through connector is connected to the third mixer channel "Y" which is panned left, the inverted connector is connected to the fourth mixer channel "-Y" which is panned right. Start with just the W and X channels, trim the channel gain controls so that a cardioid (null at 180°) results when the faders are at equal positions. Confirm this by placing a sound source at the null and adjusting W and X channel gain for a deep drop in pickup toward the rear. Now move the sound toward the front of the mic and begin to increase the level of the Y and -Y channels. Adjusting the relative levels of Y and -Y will shift the image left and right ("pan" or "balance") and adjusting the ratio of the Y signals to the W/X signals will adjust the "width" or "focus."

Using a basic mixing console or digital audio workstation, you can derive all of the channels needed for stereo, center-channel-stereo, 5.1 or 7.1 surround. In practice, the mixdown or balance engineer will want to adjust the ratios to produce a convincing sound image, but these basic relationships for surround are a good starting point:

Left Front = W+X+Y	Left Rear = W-X+Y
Center Front = W+X	Right Rear = W-X-Y
Right Front = W+X-Y	Low Frequency Effects = W (lowpass filtered)

Mixing for Surround

A practical way to derive surround channel mixes from raw C700S W, X and Y signals uses a mixer or DAW with multiple aux busses. Three busses are sufficient if the channel strips have the capability of reversing phase from the busses; if they don't, you'll need five busses, one each for W, X, -X, Y and -Y.

If you use digital processing to produce the "inverted" signals, be certain that the DSP doesn't introduce unwanted phase anomalies in the signal due to changes in processing latency. Many digital workstations have variable delay depending on the amount of processing being done. This would cause shifts in stereo imaging due to differences in phase between the channels.

Appendix A - C700S Control Console (not included)

Josephson designed a microphone preamplifier/control console for use with the C700S. It was never put into production, as users have opted to record the tracks independently and mix down using their normal processing tools. The block diagram of the console is shown here for reference, as it explains the process in analog terms. Five outputs are provided, each with independent pattern and rotation controls. A sixth output, for "low frequency effects" may be derived from the W channel through a low-pass filter.

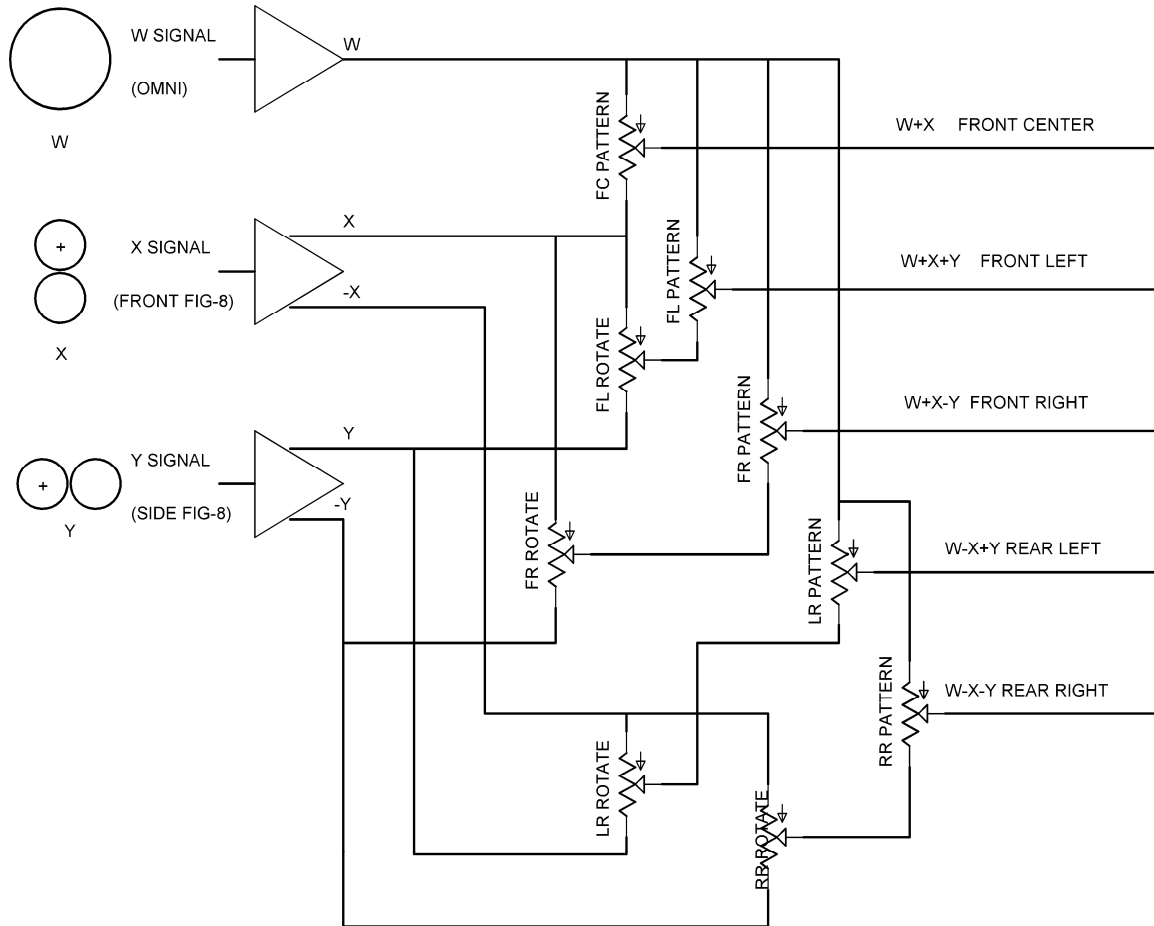

Appendix B – For the mathematically inclined

The omni or W microphone signal behaves as a monopole scalar pressure transducer, unaffected by direction (at low and mid frequencies, where the size of the microphone housing isn't a significant fraction of a wavelength). The figure-8 (X and Y) microphone signals behave as dipole transducers with a response that varies with cosine of the arrival angle. In the C700S, we use a combination of the two figure-8 signals X and Y to yield a new figure-8 pattern D pointed at a defined angle θ . We use capital letters to refer to the signals themselves and lower-case to refer to the proportions of each signal in a mixture.

For these formulas, consider the output as a combination of W and D signals where $w+d=1$. Some common ratios are

Omni: all W
 Subcardioid/hypocardioid/wide cardioid: $0.66W+0.33D$
 Cardioid: $0.5W+0.5D$
 Hypercardioid: $0.33W+0.66D$
 Supercardioid: $0.25W+0.75D$
 Figure-8: all D

Steering or rotation of D is achieved by adding X and Y signals. The main axis of the pattern is located at an angle ϕ relative to the front of the microphone. ϕ changes linearly from 0 to 90° by varying the ratio of X to Y signals in the mix. For a ratio of x and y such that $x+y=1$, $\phi=90y$.

ϕ	X	Y
90° left	0	1
45° left	.5	.5
0°	1	0
45° right	.5	-.5
90° right	0	-1

ϕ is not restricted to the front quadrants. By reversing the phase of the X signal, it can be pointed to the rear. ϕ lies within one of the four quadrants depending on the phase of the X and Y components. In the C700A there is no Y signal, so ϕ is fixed at 0 or 180° depending on whether X or -X is used.

X+Y	X+ -Y
LF	RF
LR	RR
-X + Y	-X + -Y

The response r at azimuth angle θ (where θ is the angle from the main axis of D) is found with the formula $r(\theta) = w + d \cos(\theta)$.

Appendix C1 – Recording Direct to Stereo (cable not included)

It is possible to make a basic stereo recording with an ordinary mixer without using the advanced capability of the C700S, see "Stereo on a Simple Mixer" above. The phase-reversing wye cord that's needed for this is shown below.

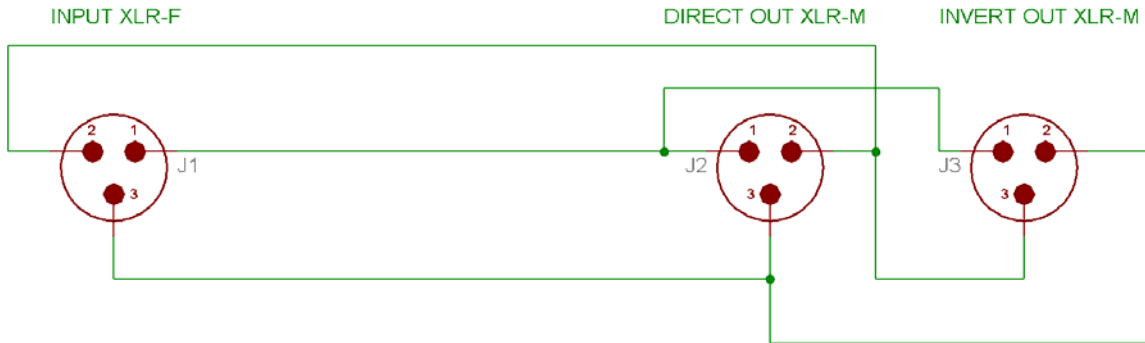

Appendix C2 – Output Adapter Cable for C700 (furnished with microphone)

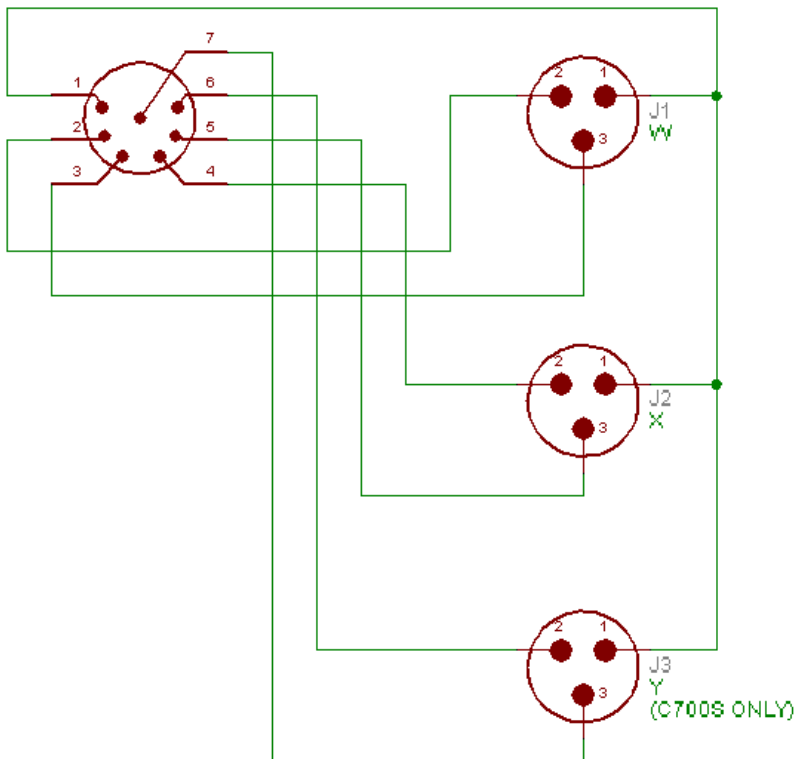

This is the standard output breakout cable furnished with the microphone.

Warranty

Josephson microphones are warranted to be free of defects for five years from the date of original purchase. If purchase documents are not available, the warranty period begins when the microphone was shipped from the factory. Josephson Engineering will, at its option, repair or replace any microphone that fails, providing that it is returned to the factory prepaid and has not been abused or altered.

There are no user-serviceable parts inside Josephson Engineering microphones. Disassembling a Josephson microphone will void its warranty.

For service information please contact Josephson at 831-420-0888. Repair shipments may be sent to:

Josephson Engineering, Inc.
329A Ingalls St
Santa Cruz CA 95060

RoHS Certification

Josephson Engineering, Inc. certifies that the C700A and C700S microphones bearing the CE mark conform to the applicable requirements of the European Union directives as follows:

Machinery 93/68/EEC	Exempt – passive sensor
Low Voltage 93/68/EEC	Exempt – passive sensor
EMC 93/68/EEC	Exempt – passive sensor

RoHS 2002/95/EEC	Compliant for Hg, Cd, Cr6, PB, PBDE and Pb
------------------	--------------------------------------------

